

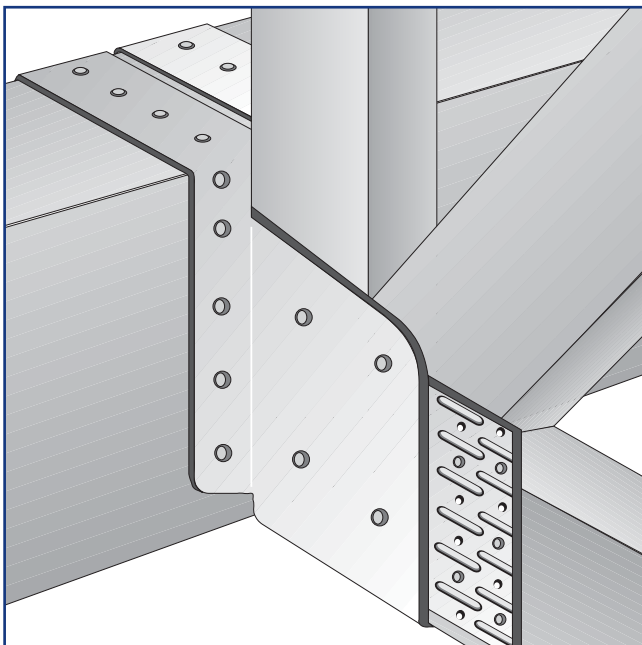

# JOIST HANGERS

## SPEEDY GIRDER TRUSS SHOE



Designed to offer a safe and economical method of connecting trusses to girder units. It incorporates a specifically extended bearing surface of 85mm.

**AVAILABLE IN THE FOLLOWING WIDTHS:**  
38mm, 44mm 50mm & 75mm

**QTY PER BAG/BOX**  
32

Speedy Joist Hangers provide a quick and safe method of joist trimming for light, medium and heavy duty joists. The unparalleled range of BAT trimming hangers are designed to meet every joist connecting application likely to occur.

Fixing sequence for speedy standard and girder truss shoe.

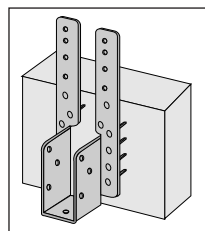

Stage 1

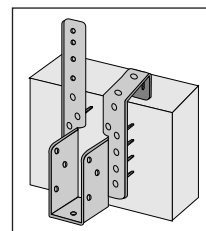

Stage 2

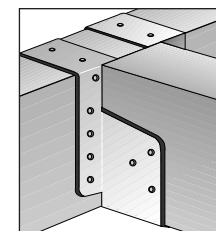

Stage 3

Timbers should be fixed through all nail holes provided using BAT 30mm long x 9smg square twisted sheradised nails.

Type	Joist Width (mm)	Leg Length (mm)	Side Gusset (mm)	SWL (kn)
Speedy Minor	38, 44, 50	64	64	1.6
Speedy Standard	38, 44, 50, 63, 75, 88, 100	281 to 262	114 to 95	4.3
Long leg Speedy	38, 50	390 to 396	113 to 107	6.7
Girder Truss	38, 44, 50, 75	271 to 252	115 to 96	7.1
Maxi Speedy	38, 44, 50, 63, 75, 88, 100, 150	70 to 235	Variable	On application



Galtee Valley Enterprise Park, Ballylanders, Co. Limerick  
Tel: 062 46290, Fax: 062 46291, E-mail: info@batmetalwork.com

[www.batmetalwork.com](http://www.batmetalwork.com)