

R-RBL Rawlbolt® - Loose Bolt for use in hollow core slab and ceramic substrates

World's most popular all-purpose expanding shield anchor - loose bolt version



Product information

Features and benefits

- RAWLBOLT® - first ever mechanical anchor in the world, forerunner of all of the later mechanical anchors
- For use in cracked and non-cracked concrete (ETA option 1), hollow-core slabs, flooring blocks and ceramics
- Three-pieces expanding sleeve of maximum expansion provides optimal load and safety of use in any substrate
- Wide range of diameters (M6 to M20)

Applications

- Roller shutter doors
- Fire doors
- Structural steelwork
- Security grills
- Heavy machinery
- Pipework/ductwork supports

Base materials

Approved for use in:

- Solid clay brick $\geq 20\text{MPa}$
- Hollow Lightweight Concrete Block LAC 5 $\geq 5\text{MPa}$
- Hollow Sand-lime Brick $\geq 15\text{MPa}$
- Concrete hollow floor block (eg. Teriva)
- Hollow-core Slab C20/25
- Hollow-core Slab C30/37-C50/60

Installation guide

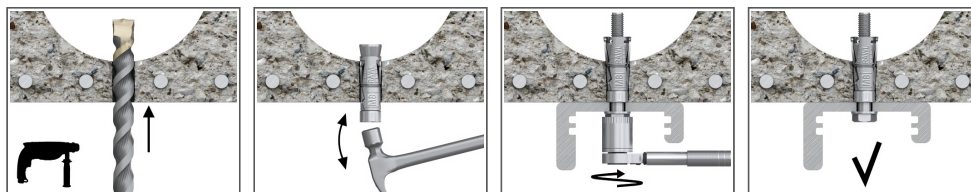

1. Drill a hole of required diameter and depth
2. Remove pre-assembled bolt and washer. Insert shield into hole and tap home with hammer until flush with surface
3. Insert bolt with washer through fixture into the shield
4. Tighten to the recommended torque

Product information

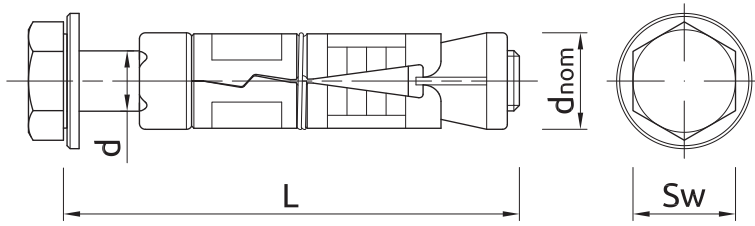

Size	Product Code	Anchor			Fixture	
		Diameter	External diameter	Length	Max. thickness	Hole diameter
		d [mm]	d _{nom} [mm]	L [mm]	t _{fix} [mm]	d _f [mm]
M6	R-RBL-M06/25W	6	12	70	25	6.5
	R-RBL-M06/40W	6	12	85	40	6.5
M8	R-RBL-M08/10W	8	14	65	10	9
	R-RBL-M08/25W	8	14	80	25	9
	R-RBL-M08/40W	8	14	95	40	9
M10	R-RBL-M10/10W	10	16	75	10	11
	R-RBL-M10/25W	10	16	90	25	11
	R-RBL-M10/50W	10	16	115	50	11
	R-RBL-M10/75W	10	16	140	75	11
M12	R-RBL-M12/10W	12	20	90	10	13
	R-RBL-M12/25W	12	20	105	25	13
	R-RBL-M12/40W	12	20	120	40	13
	R-RBL-M12/60W	12	20	140	60	13
M16	R-RBL-M16/15W	16	25	135	15	17
	R-RBL-M16/30W	16	25	150	30	17
	R-RBL-M16/60W	16	25	180	60	17
M20	R-RBL-M20/60W	20	32	195	60	22
	R-RBL-M20/100W	20	32	235	110	22

Installation data

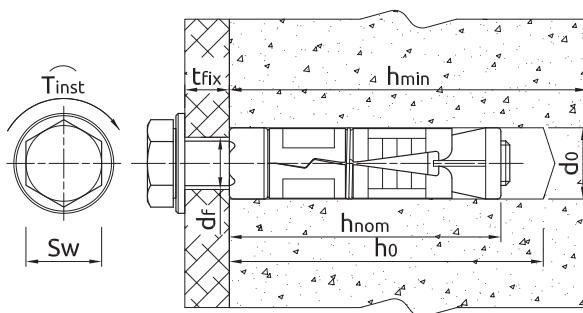

Installation in solid substrate

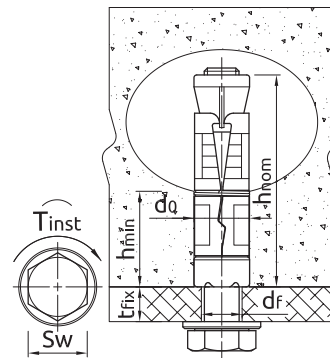

Installation in hollow substrate

Size	M6	M8	M10	M12	M16	M20
Thread diameter	d	8	10	12	16	20
Hole diameter in substrate	d ₀	14	16	20	25	32
Min. installation depth	h _{nom}	45	50	60	120	135
Min. hole depth in substrate	h ₀	50	55	65	125	140
Wrench size	Sw	10	13	17	24	30

Installation data

Size			M6	M8	M10	M12	M16	M20
SOLID SUBSTRATES								
Installation torque	T_{inst}	[Nm]	6.5	15	27	50	120	230
Min. substrate thickness	h_{min}	[mm]	100	100	100	100	142	172
Min. spacing	s_{min}	[mm]	35	40	50	60	95	115
Min. edge distance	c_{min}	[mm]	53	60	75	90	143	173
CERAMIC AND HOLLOW SUBSTRATES								
Installation torque	T_{inst}	[Nm]	3	5	8	10	15	20
Min. spacing	s_{min}	[mm]	100	100	100	100	100	115
Min. edge distance	c_{min}	[mm]	100	100	100	100	143	173

Mechanical properties

Size			M6	M8	M10	M12	M16	M20
Nominal ultimate tensile strength - tension	f_{uk}	[N/mm ²]	500	500	500	500	500	500
Nominal yield strength - tension	f_{yk}	[N/mm ²]	400	400	400	400	400	400
Cross sectional area - tension	A_s	[mm ²]	20.1	36.6	58	84.3	157	245
Elastic section modulus	W_{el}	[mm ³]	21.21	50.27	98.17	169.65	402.12	785.4
Characteristic bending resistance	$M^o_{Rk,s}$	[Nm]	12.72	30.16	58.9	101.79	241.27	471.24
Design bending resistance	M	[Nm]	10.18	24.13	47.12	81.43	193.02	376.99

Basic performance data

Performance data for single anchor without influence of edge distance and spacing

Size			M6	M8	M10	M12	M16	M20
CHARACTERISTIC LOAD								
TENSION LOAD N_{rk}								
Hollow core slab min. C20/25								
Wall thickness	Material class							
23	C30/37	[kN]	4.00	4.50	-	-	-	-
	C35/45	[kN]	2.00	4.50	-	-	-	-
	C45/55	[kN]	2.00	4.50	-	-	-	-
	C50/60	[kN]	2.00	4.50	-	-	-	-
35	C30/37	[kN]	6.50	11.00	16.00	-	-	-
	C35/45	[kN]	7.00	12.00	17.00	-	-	-
	C45/55	[kN]	8.00	14.00	19.00	-	-	-
	C50/60	[kN]	8.50	15.00	20.00	-	-	-
40	C30/37	[kN]	7.00	16.00	19.00	24.00	-	-
	C35/45	[kN]	8.00	18.00	20.00	28.00	-	-
	C45/55	[kN]	8.50	20.00	22.00	30.00	-	-
	C50/60	[kN]	9.50	22.00	24.00	32.00	-	-
50	C20/25	[kN]	8.00	8.50	8.50	8.50	8.50	8.50
Beam-and-block floor (eg.Terriva 4.0/2), min. 25mm wall thickness		[kN]	1.20	2.00	-	-	-	-
Lightweight concrete LAC class 5		[kN]	5.50	5.50	5.50	5.50	-	-
Solid clay brick class 20		[kN]	6.00	6.00	6.00	6.00	-	-
Silicate hollow block class 15		[kN]	1.50	-	-	-	-	-
SHEAR LOAD V_{rk}								
Hollow core slab min. C20/25								
Wall thickness	Material class							
23	C30/37	[kN]	4.00	4.50	-	-	-	-
	C35/45	[kN]	2.00	4.50	-	-	-	-
	C45/55	[kN]	2.00	4.50	-	-	-	-
	C50/60	[kN]	2.00	4.50	-	-	-	-
35	C30/37	[kN]	5.00	9.00	14.00	-	-	-
	C35/45	[kN]	5.00	9.00	14.00	-	-	-
	C45/55	[kN]	5.00	9.00	14.00	-	-	-
	C50/60	[kN]	5.00	9.00	14.00	-	-	-
40	C30/37	[kN]	5.00	9.00	14.00	20.00	-	-
	C35/45	[kN]	5.00	9.00	14.00	20.00	-	-
	C45/55	[kN]	5.00	9.00	14.00	20.00	-	-
	C50/60	[kN]	5.00	9.00	14.00	20.00	-	-
50	C20/25	[kN]	5.00	8.50	8.50	8.50	8.50	8.50
Beam-and-block floor (eg.Terriva 4.0/2), min. 25mm wall thickness		[kN]	1.20	2.00	-	-	-	-
Lightweight concrete LAC class 5		[kN]	5.00	5.50	5.50	5.50	-	-
Solid clay brick class 20		[kN]	5.00	6.00	6.00	6.00	-	-
Silicate hollow block class 15		[kN]	1.50	-	-	-	-	-

Basic performance data

Size			M6	M8	M10	M12	M16	M20
DESIGN LOAD								
TENSION LOAD N_{rd}								
Hollow core slab min. C20/25								
Wall thickness	Material class							
23	C30/37	[kN]	2.20	2.50	-	-	-	-
	C35/45	[kN]	1.10	2.50	-	-	-	-
	C45/55	[kN]	1.10	2.50	-	-	-	-
	C50/60	[kN]	1.10	2.50	-	-	-	-
35	C30/37	[kN]	3.60	6.10	8.90	-	-	-
	C35/45	[kN]	3.90	6.70	9.40	-	-	-
	C45/55	[kN]	4.40	7.80	10.60	-	-	-
	C50/60	[kN]	4.70	8.30	11.10	-	-	-
40	C30/37	[kN]	3.90	8.90	10.60	13.30	-	-
	C35/45	[kN]	4.40	10.00	11.10	15.60	-	-
	C45/55	[kN]	4.70	11.10	12.20	16.70	-	-
	C50/60	[kN]	5.30	12.20	13.30	17.80	-	-
50	C20/25	[kN]	4.40	4.70	4.70	4.70	4.70	4.70
Beam-and-block floor (eg.Terriva 4.0/2), min. 25mm wall thickness		[kN]	0.70	1.10	-	-	-	-
Lightweight concrete LAC class 5		[kN]	2.00	2.20	2.20	2.20	-	-
[English]: Cegła ceramiczna pełna 20MPa		[kN]	2.00	2.40	2.40	2.40	-	-
Silicate hollow block class 15		[kN]	0.60	-	-	-	-	-
SHEAR LOAD V_{rd}								
Hollow core slab min. C20/25								
Wall thickness	Material class							
23	C30/37	[kN]	3.20	3.60	-	-	-	-
	C35/45	[kN]	1.60	3.60	-	-	-	-
	C45/55	[kN]	1.60	3.60	-	-	-	-
	C50/60	[kN]	1.60	3.60	-	-	-	-
35	C30/37	[kN]	4.00	7.20	11.20	-	-	-
	C35/45	[kN]	4.00	7.20	11.20	-	-	-
	C45/55	[kN]	4.00	7.20	11.20	-	-	-
	C50/60	[kN]	4.00	7.20	11.20	-	-	-
40	C30/37	[kN]	4.00	7.20	11.20	16.00	-	-
	C35/45	[kN]	4.00	7.20	11.20	16.00	-	-
	C45/55	[kN]	4.00	7.20	11.20	16.00	-	-
	C50/60	[kN]	4.00	7.20	11.20	16.00	-	-
50	C20/25	[kN]	4.00	6.80	6.80	6.80	6.80	6.80
Beam-and-block floor (eg.Terriva 4.0/2), min. 25mm wall thickness		[kN]	1.00	1.60	-	-	-	-
Lightweight concrete LAC class 5		[kN]	4.00	4.40	4.40	4.40	-	-
[English]: Cegła ceramiczna pełna 20MPa		[kN]	4.00	4.80	4.80	4.80	-	-
Silicate hollow block class 15		[kN]	1.20	-	-	-	-	-

Basic performance data

Size			M6	M8	M10	M12	M16	M20
RECOMMENDED LOAD								
TENSION LOAD N_{rec}								
Hollow core slab min. C20/25								
Wall thickness	Material class							
23	C30/37	[kN]	1.60	1.80	-	-	-	-
	C35/45	[kN]	0.80	1.80	-	-	-	-
	C45/55	[kN]	1.60	1.80	-	-	-	-
	C50/60	[kN]	0.80	1.80	-	-	-	-
35	C30/37	[kN]	2.60	4.40	6.30	-	-	-
	C35/45	[kN]	2.80	4.80	6.70	-	-	-
	C45/55	[kN]	3.20	5.60	7.50	-	-	-
	C50/60	[kN]	3.40	6.00	7.90	-	-	-
40	C30/37	[kN]	2.80	6.30	7.50	9.50	-	-
	C35/45	[kN]	3.20	7.10	7.90	11.10	-	-
	C45/55	[kN]	3.40	7.90	8.70	11.90	-	-
	C50/60	[kN]	3.80	8.70	9.50	12.70	-	-
50	C20/25	[kN]	3.20	3.40	3.40	3.40	3.40	3.40
Beam-and-block floor (eg.Terriva 4.0/2), min. 25mm wall thickness		[kN]	0.50	0.80	-	-	-	-
Lightweight concrete LAC class 5		[kN]	1.40	1.60	1.60	1.60	-	-
[English]: Cegła ceramiczna pełna 20MPa		[kN]	1.40	1.70	1.70	1.70	-	-
Silicate hollow block class 15		[kN]	0.40	-	-	-	-	-
SHEAR LOAD V_{rec}								
Hollow core slab min. C20/25								
Wall thickness	Material class							
23	C30/37	[kN]	2.30	2.60	-	-	-	-
	C35/45	[kN]	1.10	2.60	-	-	-	-
	C45/55	[kN]	1.10	2.60	-	-	-	-
	C50/60	[kN]	1.10	2.60	-	-	-	-
35	C30/37	[kN]	2.90	5.10	8.00	-	-	-
	C35/45	[kN]	2.90	5.10	8.00	-	-	-
	C45/55	[kN]	2.90	5.10	8.00	-	-	-
	C50/60	[kN]	2.90	5.10	8.00	-	-	-
40	C30/37	[kN]	2.90	5.10	8.00	11.40	-	-
	C35/45	[kN]	2.90	5.10	8.00	11.40	-	-
	C45/55	[kN]	2.90	5.10	8.00	11.40	-	-
	C50/60	[kN]	2.90	5.10	8.00	11.40	-	-
50	C20/25	[kN]	2.90	4.90	4.90	4.90	4.90	4.90
Beam-and-block floor (eg.Terriva 4.0/2), min. 25mm wall thickness		[kN]	0.70	1.10	-	-	-	-
Lightweight concrete LAC class 5		[kN]	2.90	3.10	3.10	3.10	-	-
[English]: Cegła ceramiczna pełna 20MPa		[kN]	2.90	3.40	3.40	3.40	-	-
Silicate hollow block class 15		[kN]	0.90	-	-	-	-	-

Product commercial data

Product Code	Anchor		Quantity [pcs]			Weight [kg]			Bar Codes
	Diameter [mm]	Length [mm]	Box	Outer	Pallet	Box	Outer	Pallet	
R-RBL-M06/25W	6	70	50	400	16000	1.65	13.2	556.4	5906675283234
R-RBL-M06/40W	6	85	50	50	8000	1.81	1.81	319.6	5906675283258
R-RBL-M08/10W	8	65	50	400	16000	2.7	21.6	895.6	5906675283272
R-RBL-M08/25W	8	80	50	50	8000	3.0	3.0	502.0	5906675283296
R-RBL-M08/40W	8	95	50	50	8000	3.2	3.2	541.2	5906675283319
R-RBL-M10/10W	10	75	50	50	8000	4.6	4.6	765.2	5906675283333
R-RBL-M10/25W	10	90	50	50	8000	5.0	5.0	832.4	5906675283357
R-RBL-M10/50W	10	115	50	50	6000	5.6	5.6	705.6	5906675283371
R-RBL-M10/75W	10	140	50	50	8000	6.4	6.4	1054.0	5906675283395
R-RBL-M12/10W	12	90	25	25	4000	4.2	4.2	700.4	5906675283401
R-RBL-M12/25W	12	105	25	25	4000	4.5	4.5	749.6	5906675283418
R-RBL-M12/40W	12	120	25	25	3000	4.9	4.9	614.7	5906675283425
R-RBL-M12/60W	12	140	25	25	4000	5.2	5.2	862.0	5906675283432
R-RBL-M16/15W	16	135	10	10	1600	4.2	4.2	693.5	5906675283449
R-RBL-M16/30W	16	150	10	10	1600	4.4	4.4	734.3	5906675283456
R-RBL-M16/60W	16	180	10	10	1200	4.8	4.8	608.3	5906675283463
R-RBL-M20/60W	20	195	10	10	1200	9.0	9.0	1113.5	5906675283487
R-RBL-M20/100W	20	235	10	10	1200	9.8	9.8	1207.8	5906675283470