

R-RBP Rawlbolt® - Bolt Projecting for use in cracked and non-cracked concrete

World's most popular all-purpose expanding shield anchor - bolt projecting version

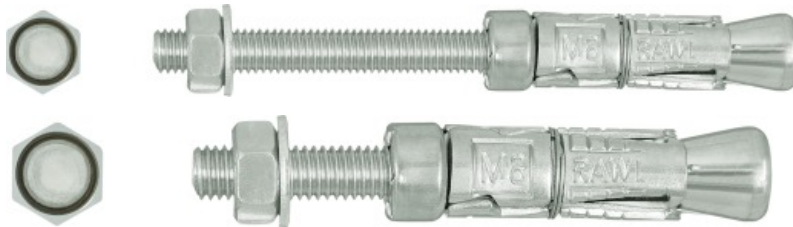

Approvals and Reports

- ETA-11/0479



Product information

Features and benefits

- RAWLBOLT® - first ever mechanical anchor in the world, forerunner of all of the later mechanical anchors
- For use in cracked and non-cracked concrete (ETA option 1), hollow-core slabs, flooring blocks and ceramics
- Product recommended for applications requiring fire resistance
- Three-pieces expanding sleeve of maximum expansion provides optimal load and safety of use in any substrate
- Wide range of diameters (M6 to M20)

Applications

- Roller shutter doors
- Fire doors
- Steelwork
- Security grills
- Heavy machinery
- Pipework/duct work support

Base materials

Approved for use in:

- Cracked concrete C20/25-C50/60
- Non-cracked concrete C20/25-C50/60
- Unreinforced concrete
- Reinforced concrete

Also suitable for use in:

- Solid clay brick $\geq 20\text{MPa}$
- Hollow Lightweight Concrete Block LAC $5 \geq 5\text{MPa}$
- Hollow Sand-lime Brick $\geq 15\text{MPa}$
- Concrete hollow floor block (eg. Teriva)
- Hollow-core Slab C20/25
- Hollow-core Slab C30/37-C50/60

Installation guide

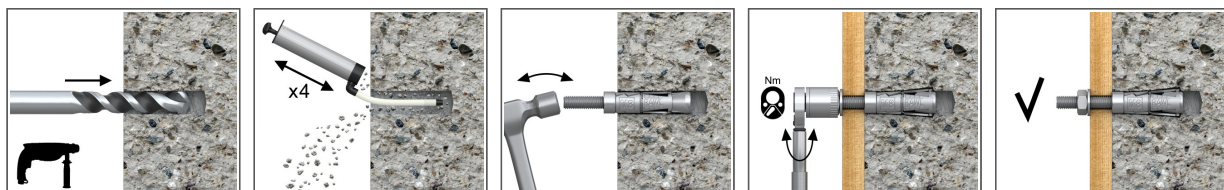

1. Drill a hole of required diameter and depth. Note: When fixing into brickwork, mortar joints should be avoided
2. Clear the hole of drilling dust and debris (using blowpump or equivalent method)
3. Remove nut and washer and insert anchor into hole. Tap home with hammer until flush with surface
4. Position fixture over the projecting bolt
5. Add washer and nut and tighten to recommended torque

Product information

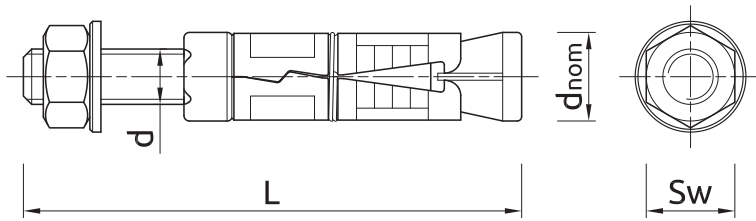

Size	Product Code	Approval type	Anchor			Fixture		Anchor	Fixture
			Diameter	External diameter	Length	Max. thickness	Hole diameter	Thread diameter	Min. thickness
			d	d _{nom}	L	t _{fix}	d _f	d	t _{fix}
			[mm]	[mm]	[mm]	[mm]	[mm]	[mm]	[mm]
M6	R-RBP-M06/10W	ETA-11/04 79	6	12	65	10	6,5	-	-
	R-RBP-M06/25W	ETA-11/04 79	6	12	80	25	6,5	-	-
	R-RBP-M06/60W	ETA-11/04 79	6	12	115	60	6,5	-	-
M8	R-RBP-M08/10W	ETA-11/04 79	8	14	75	10	9	-	-
	R-RBP-M08/25W	ETA-11/04 79	8	14	90	25	9	-	-
	R-RBP-M08/60W	ETA-11/04 79	8	14	125	60	9	-	-
M10	R-RBP-M10/15W	ETA-11/04 79	10	16	90	15	11	-	-
	R-RBP-M10/30W	ETA-11/04 79	10	16	105	30	11	-	-
	R-RBP-M10/60W	ETA-11/04 79	10	16	135	60	11	-	-
M12	R-RBP-M12/15W	ETA-11/04 79	12	20	110	15	13	-	-
	R-RBP-M12/30W	ETA-11/04 79	12	20	125	30	13	-	-
	R-RBP-M12/75W	ETA-11/04 79	12	20	170	75	13	-	-
M16	R-RBP-M16/15W	ETA-11/04 79	16	25	150	15	17	-	-
	R-RBP-M16/35W	ETA-11/04 79	16	25	170	35	17	-	-
	R-RBP-M16/75W	ETA-11/04 79	16	25	210	75	17	-	-
M20	R-RBP-M20/15W	ETA-11/04 79	20	32	170	15	22	-	-
	R-RBP-M20/30W	ETA-11/04 79	20	32	185	30	22	-	-
	R-RBP-M20/100W	ETA-11/04 79	20	32	255	100	22	-	-
M24	R-RBP-M24/75W	-	24	38	255	75	26	75	-

Installation data

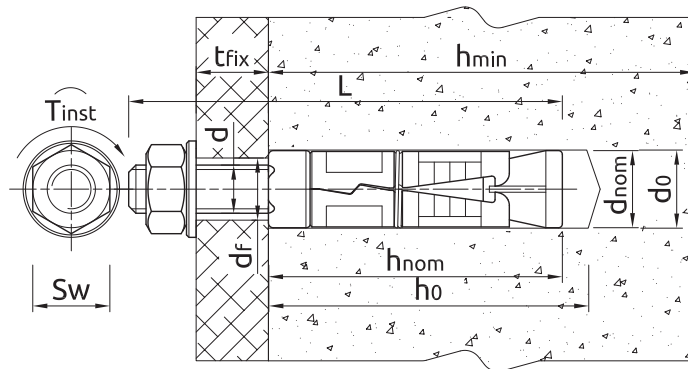

Size	M6	M8	M10	M12	M16	M20		
Thread diameter	d	[mm]	6	8	10	12	16	20
Hole diameter in substrate	d ₀	[mm]	12	14	16	20	25	32
Installation torque	T _{inst}	[Nm]	6.5	15	27	50	120	230
Wrench size	Sw	[mm]	10	13	17	19	24	30
Min. hole depth in substrate	h ₀	[mm]	50	55	65	85	125	140
Min. installation depth	h _{nom}	[mm]	45	50	60	80	120	135
Min. substrate thickness	h _{min}	[mm]	100	100	100	100	142.5	172.5
Min. spacing	s _{min}	[mm]	35	40	50	60	95	115
Min. edge distance	c _{min}	[mm]	53	60	75	90	143	173

Mechanical properties

Size	M6	M8	M10	M12	M16	M20		
Nominal ultimate tensile strength - tension	f _{uk}	[N/mm ²]	500	500	500	500	500	
Nominal yield strength - tension	f _{yk}	[N/mm ²]	400	400	400	400	400	
Cross sectional area - tension	A _s	[mm ²]	20.1	36.6	58	84.3	157	245
Elastic section modulus	W _{el}	[mm ³]	21.21	50.27	98.17	169.65	402.12	785.4
Characteristic bending resistance	M ⁰ _{Rk,s}	[Nm]	12.72	30.16	58.9	101.79	241.27	471.24
Design bending resistance	M	[Nm]	10.18	24.13	47.12	81.43	193.02	376.99

Basic performance data

Performance data for single anchor without influence of edge distance and spacing

Size	M6	M8	M10	M12	M16	M20	
NON-CRACKED CONCRETE							
Effective embedment depth h _{ef}	[mm]	35.00	40.00	50.00	60.00	95.00	115.00
CRACKED CONCRETE							
Effective embedment depth h _{ef}	[mm]	35.00	40.00	50.00	60.00	95.00	115.00
MEAN ULTIMATE LOAD							
TENSION LOAD N_{Ru,m}							
NON-CRACKED CONCRETE	[kN]	7.80	8.35	15.24	18.48	48.77	56.55
CRACKED CONCRETE	[kN]	5.20	6.50	7.80	15.60	20.80	34.16
SHEAR LOAD V_{Ru,m}							
NON-CRACKED CONCRETE	[kN]	5.53	10.07	15.95	23.19	43.18	67.38
CRACKED CONCRETE	[kN]	5.53	10.07	15.95	23.19	43.18	67.38

Basic performance data

Size		M6	M8	M10	M12	M16	M20
CHARACTERISTIC LOAD							
TENSION LOAD N_{Rk}							
NON-CRACKED CONCRETE	[kN]	6.00	7.50	12.00	16.00	40.00	50.00
CRACKED CONCRETE	[kN]	4.00	5.00	6.00	12.00	16.00	30.00
SHEAR LOAD V_{Rk}							
NON-CRACKED CONCRETE	[kN]	5.03	9.15	14.50	21.08	39.25	61.25
CRACKED CONCRETE	[kN]	5.03	8.71	12.17	21.08	39.25	61.25
DESIGN LOAD							
TENSION LOAD N_{Rd}							
NON-CRACKED CONCRETE	[kN]	3.33	4.17	6.67	8.89	22.22	27.78
CRACKED CONCRETE	[kN]	2.22	2.78	3.33	6.67	8.89	16.67
SHEAR LOAD V_{Rd}							
NON-CRACKED CONCRETE	[kN]	4.02	7.32	11.60	16.86	31.40	49.00
CRACKED CONCRETE	[kN]	4.02	5.81	8.12	16.86	31.40	49.00

Design performance data

(-) failure is not decisive

Size		M6	M8	M10	M12	M16	M20
Effective embedment depth	h_{ef} [mm]	35.00	40.00	50.00	60.00	95.00	115.0
TENSION LOAD							
STEEL FAILURE							
Characteristic resistance	$N_{Rk,s}$ [kN]	10.05	18.30	29.00	42.15	78.50	122.5
Partial safety factor	γ_{Ms} -	1.50	1.50	1.50	1.50	1.50	1.50
PULL-OUT FAILURE; NON-CRACKED CONCRETE C20/25							
Characteristic resistance	$N_{Rk,p}$ [kN]	6.00	7.50	12.00	16.00	40.00	50.00
PULL-OUT FAILURE; CRACKED CONCRETE C20/25							
Characteristic resistance	$N_{Rk,p}$ [kN]	4.00	5.00	6.00	12.00	16.00	30.00
PULL-OUT FAILURE							
Installation safety factor	γ_{inst} -	1.20	1.20	1.20	1.20	1.20	1.20
Increasing factors for $N_{Rd,p}$ - C30/37	ψ_c -	1.22	1.22	1.22	1.22	1.22	1.22
Increasing factors for $N_{Rd,p}$ - C40/50	ψ_c -	1.41	1.41	1.41	1.41	1.41	1.41
Increasing factors for $N_{Rd,p}$ - C50/60	ψ_c -	1.55	1.55	1.55	1.55	1.55	1.55
CONCRETE CONE FAILURE							
Factor for cracked concrete	$k_{cr,N}$ -	7.70	7.70	7.70	7.70	7.70	7.70
Factor for non-cracked concrete	$k_{ucr,N}$ -	11.00	11.00	11.00	11.00	11.00	11.00
Installation safety factor	γ_{inst} -	1.20	1.20	1.20	1.20	1.20	1.20
Spacing	$s_{cr,N}$ [mm]	105.0	120.0	150.0	180.0	285.0	345.0
Edge distance	$c_{cr,N}$ [mm]	52.50	60.00	75.00	90.00	143.0	173.0
CONCRETE SPLITTING FAILURE							
Spacing	$s_{cr,sp}$ [mm]	105.0	120.0	150.0	180.0	285.0	345.0
Edge distance	$c_{cr,sp}$ [mm]	53.00	60.00	75.00	90.00	143.0	173.0
Installation safety factor	γ_{inst} -	1.20	1.20	1.20	1.20	1.20	1.20

Design performance data

Size			M6	M8	M10	M12	M16	M20
SHEAR LOAD								
STEEL FAILURE								
Characteristic resistance without lever arm	$V_{Rk,s}$	[kN]	5.03	9.15	14.50	21.08	39.25	61.25
Ductility factor	k_γ	-	0.80	0.80	0.80	0.80	0.80	0.80
Characteristic resistance with lever arm	$M_{Rk,s}$	[Nm]	7.63	18.74	37.39	65.52	166.5	324.6
Partial safety factor	γ_{Ms}	-	1.25	1.25	1.25	1.25	1.25	1.25
CONCRETE PRY-OUT FAILURE								
Factor	k	-	1.00	1.00	1.00	2.00	2.00	2.00
Installation safety factor	γ_{inst}	-	1.00	1.00	1.00	1.00	1.00	1.00
CONCRETE EDGE FAILURE								
Effective length of anchor	ℓ_f	[mm]	35.00	40.00	50.00	60.00	95.00	115.0
Anchor diameter	d_{nom}	[mm]	6.00	8.00	10.00	12.00	16.00	20.00
Installation safety factor	γ_{inst}	-	1.00	1.00	1.00	1.00	1.00	1.00

Design performance data

Resistance to tension and shear loads under fire exposure

Size			M6	M8	M10	M12	M16	M20
R (for EI) = 30 min								
Effective embedment depth	h_{ef}	[mm]	35.00	40.00	50.00	60.00	95.00	115.00
TENSION LOAD								
STEEL FAILURE								
Characteristic resistance	$N_{Rk,s}$	[kN]	0.20	0.40	0.90	1.70	3.10	4.90
PULL-OUT FAILURE								
Characteristic resistance	$N_{Rk,p}$	[kN]	1.00	1.30	1.50	3.00	4.00	7.50
SHEAR LOAD								
STEEL FAILURE								
Characteristic resistance without lever arm	$V_{Rk,s}$	[kN]	0.20	0.40	0.90	1.70	3.10	4.90
Characteristic resistance with lever arm	$M_{Rk,s}$	[Nm]	0.20	0.40	1.10	2.60	6.70	13.00
R (for EI) = 60 min								
Effective embedment depth	h_{ef}	[mm]	35.00	40.00	50.00	60.00	95.00	115.00
TENSION LOAD								
STEEL FAILURE								
Characteristic resistance	$N_{Rk,s}$	[kN]	0.20	0.30	0.80	1.30	2.40	3.70
PULL-OUT FAILURE								
Characteristic resistance	$N_{Rk,p}$	[kN]	1.00	1.30	1.50	3.00	4.00	7.50
SHEAR LOAD								
STEEL FAILURE								
Characteristic resistance without lever arm	$V_{Rk,s}$	[kN]	0.20	0.30	0.80	1.30	2.40	3.70
Characteristic resistance with lever arm	$M_{Rk,s}$	[Nm]	0.10	0.30	1.00	2.00	5.00	9.70
R (for EI) = 90 min								
Effective embedment depth	h_{ef}	[mm]	35.00	40.00	50.00	60.00	95.00	115.00
TENSION LOAD								
STEEL FAILURE								
Characteristic resistance	$N_{Rk,s}$	[kN]	0.10	0.30	0.60	1.10	2.00	3.20
PULL-OUT FAILURE								
Characteristic resistance	$N_{Rk,p}$	[kN]	1.00	1.30	1.50	3.00	4.00	7.50
SHEAR LOAD								
STEEL FAILURE								
Characteristic resistance without lever arm	$V_{Rk,s}$	[kN]	0.10	0.30	0.60	1.10	2.00	3.20
Characteristic resistance with lever arm	$M_{Rk,s}$	[Nm]	0.10	0.30	0.70	1.70	4.30	8.40
R (for EI) = 120 min								
Effective embedment depth	h_{ef}	[mm]	35.00	40.00	50.00	60.00	95.00	115.00
TENSION LOAD								
STEEL FAILURE								
Characteristic resistance	$N_{Rk,s}$	[kN]	0.10	0.20	0.50	0.80	1.60	2.50
PULL-OUT FAILURE								
Characteristic resistance	$N_{Rk,p}$	[kN]	0.80	1.00	1.20	2.40	3.20	6.00
SHEAR LOAD								
STEEL FAILURE								
Characteristic resistance without lever arm	$V_{Rk,s}$	[kN]	0.10	0.20	0.50	0.80	1.60	2.50
Characteristic resistance with lever arm	$M_{Rk,s}$	[Nm]	0.10	0.20	0.60	1.30	3.30	6.50

Product commercial data

Product Code	Anchor		Quantity [pcs]			Weight [kg]			Bar Codes
	Diameter [mm]	Length [mm]	Box	Outer	Pallet	Box	Outer	Pallet	
R-RBP-M06/10W ¹⁾	6	65	50	400	16000	1.59	12.7	538.8	5906675283593
R-RBP-M06/25W ¹⁾	6	80	50	400	16000	1.73	13.8	582.0	5906675283616
R-RBP-M06/60W ¹⁾	6	115	50	50	8000	2.0	2.0	354.0	5906675283630
R-RBP-M08/10W ¹⁾	8	75	50	400	16000	2.9	22.9	946.8	5906675283654
R-RBP-M08/25W ¹⁾	8	90	50	50	8000	3.1	3.1	528.4	5906675283678
R-RBP-M08/60W ¹⁾	8	125	50	50	8000	3.7	3.7	614.8	5906675283692
R-RBP-M10/15W ¹⁾	10	90	50	50	8000	5.0	5.0	825.2	5906675283715
R-RBP-M10/30W ¹⁾	10	105	50	50	6000	5.3	5.3	666.0	5906675283739
R-RBP-M10/60W ¹⁾	10	135	50	50	8000	6.1	6.1	998.0	5906675283753
R-RBP-M12/15W ¹⁾	12	110	25	25	4000	4.6	4.6	767.2	5906675283760
R-RBP-M12/30W ¹⁾	12	125	25	25	4000	4.9	4.9	818.4	5906675283777
R-RBP-M12/75W ¹⁾	12	170	25	25	3000	5.8	5.8	721.8	5906675283784
R-RBP-M16/15W ¹⁾	16	150	10	10	1600	4.4	4.4	733.5	5906675283791
R-RBP-M16/35W ¹⁾	16	170	10	10	1600	4.7	4.7	773.5	5906675283807
R-RBP-M16/75W ¹⁾	16	210	10	10	1200	5.3	5.3	662.9	5906675283814
R-RBP-M20/15W ¹⁾	20	170	10	10	1200	8.0	8.0	985.1	5906675283821
R-RBP-M20/30W ¹⁾	20	185	10	10	1200	8.3	8.3	1030.4	5906675283838
R-RBP-M20/100W ¹⁾	20	255	10	10	1200	9.9	9.9	1219.2	5906675284781
R-RBP-M24/75W	24	255	5	5	600	7.1	7.1	887.2	5906675283852

1) ETA-11/0479